



DC/DC Ultra Wide Input Converter ECU 15 Watt SB 1x1" Series



15 Watt DC/DC Converter line with 4:1 input range and single or dual output models

DC/DC converter module with input to output isolation of 500 VDC • Pi-filter at input • Continuous short circuit proof • High efficiency • No derating up to 68°C • Low output ripple and spikes • Low silhouette • Metal case with a non conductive base plate, six-sides shielded • Remote ON/OFF • SMD technology

15 Watt DC/DC Konverter Serie mit 4:1 Eingangsbereich und Einfach- oder Doppelausgang

DC/DC Konverter-Modul mit galvanischer Trennung Eingang / Ausgang von 500 VDC • Pi-Filter am Eingang • Dauerkurzschlussfest • Hoher Wirkungsgrad • Keine Lastminderung bis zu einer Umgebungstemperatur von 68°C • Gute Werte von Ripple und Spikes • Geringe Bauhöhe • Metallgehäuse mit isolierender Bodenplatte, 6seitig abgeschirmt • Remote ON/OFF • SMD Technologie

15 Watt convertisseur CC/CC avec 4:1 d'entrée et sortie simple ou double

Module convertisseur CC/CC avec séparation galvanique entrée/sortie 500 VDC • Filtre en Pi à l'entrée • Protection courts-circuits permanente • Rendement élevé • Pas de derating jusqu' à 68°C • Ondulation résiduelle de sortie très faible • Profile bas • Boîtier en métal blindé 6 faces avec fond isolé • Remote ON/OFF • Technologie CMS

Product range		Typenübersicht			Sommaire des types		
---------------	--	----------------	--	--	--------------------	--	--

Model	Input nominal	Input range	Input current @ full load	Output Uout	Output Iout	Operating temperature	Efficiency typ.
-------	---------------	-------------	---------------------------	-------------	-------------	-----------------------	-----------------

SINGLE OUTPUT

ECU24-3V315SB	24 VDC	9...36 VDC	647 mA	3.3 VDC	4000 mA	For all models: -40...+85°C or maximum case temperature of 100°C	85%
ECU24-0515SB	24 VDC	9...36 VDC	718 mA	5.0 VDC	3000 mA		87%
ECU24-1215SB	24 VDC	9...36 VDC	718 mA	12.0 VDC	1250 mA		87%
ECU24-1515SB	24 VDC	9...36 VDC	718 mA	15.0 VDC	1000 mA		87%
ECU48-3V315SB	48 VDC	18...72 VDC	320 mA	3.3 VDC	4000 mA		86%
ECU48-0515SB	48 VDC	18...72 VDC	355 mA	5.1 VDC	3000 mA		88%
ECU48-1215SB	48 VDC	18...72 VDC	355 mA	12.0 VDC	1250 mA		88%
ECU48-1515SB	48 VDC	18...72 VDC	355 mA	15.0 VDC	1000 mA		88%

DUAL OUTPUT

ECU24-050515SB	24 VDC	9...36 VDC	718 mA	±5.0 VDC	±1500 mA	87%
ECU24-121215SB	24 VDC	9...36 VDC	718 mA	±12.0 VDC	±625 mA	87%
ECU24-151515SB	24 VDC	9...36 VDC	718 mA	±15.0 VDC	±500 mA	87%
ECU48-050515SB	48 VDC	18...72 VDC	355 mA	±5.0 VDC	±1500 mA	88%
ECU48-121215SB	48 VDC	18...72 VDC	355 mA	±12.0 VDC	±625 mA	88%
ECU48-151515SB	48 VDC	18...72 VDC	355 mA	±15.0 VDC	±500 mA	88%

El. characteristics		El. Eigenschaften		Caractéristiques él.	
---------------------	--	-------------------	--	----------------------	--

All values refer to an ambient temperature of 25°C and nominal rated values where nothing else is specified

Output voltage accuracy	Ausgangsspannungsgenauigkeit	Précision tension de sortie	±1.5% of Uout nom.	
Output voltage balance	Abgleich zwischen den Ausgängen	Balance des sorties	±2%; Dual	
Residual output ripple (BW 20 MHz)	Ausgangsspannungsrippel (BW 20 MHz)	Ondulation résiduelle de sortie (BW 20 MHz)	75 mVpp max. (3.3V, 5V,±5V) 100 mVpp max. (12V, 15V,±12/15V)	
Short circuit protection	Kurzschlussfestigkeit	Protection courts-circuits	Continuous	
No load input current	Leerlaufeingangsstrom	Courant d'entrée à vide	50/25 mA (Single 24/48 VDC) 50/25 mA (Dual 24/48 VDC)	
Line regulation (max...min)	Leitungsregulierung (max...min)	Régulation ligne (max...min)	±0.2% ;single, ±0.5% dual	
Load regulation	Lastregulierung	Régulation charge	±0.2%; single (100...25%) ±1.0%; dual (100...25%)	
Isolation voltage	Isolationsspannung	Tension d'isolement	1500 VDC	
Isolation resistance	Isolationswiderstand	Résistance d'isolement	1 GOhm	
Switching frequency	Schaltfrequenz	Fréquence de découpage	typ. 400 kHz	
MTBF (MIL-HB 217E at 25°C)	MTBF (MIL-HB 217E bei 25°C)	MTBF (MIL-HB 217E à 25°C)	TBD	
EMC Conducted	EMV Leitungsgebunden	EMC Parasite guidé	EN55022/11 Class A with external input capacitor	
Temperature coefficient	Temperaturkoeffizient	Coefficient de température	typ. ±0.03% per °C	
Storage temperature	Lagertemperatur	Température de stockage	-40...+100°C	
Soldering information	Lötinformationen	Information de soudage	260°C for 10 sec.	
Weight	Gewicht	Poids	approx. 18 g; Copper Case	

EMC information ECU24-3V310SB EN55022/11 Class A

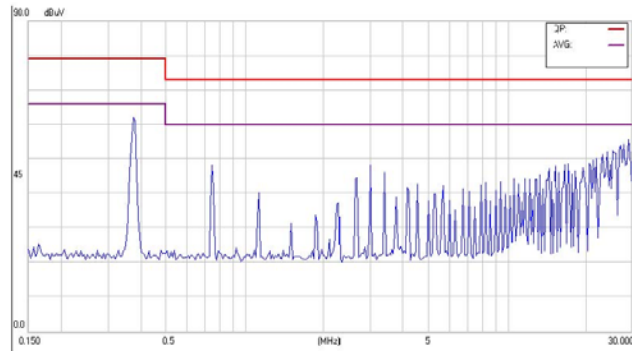

EMC measure schematic / Filter

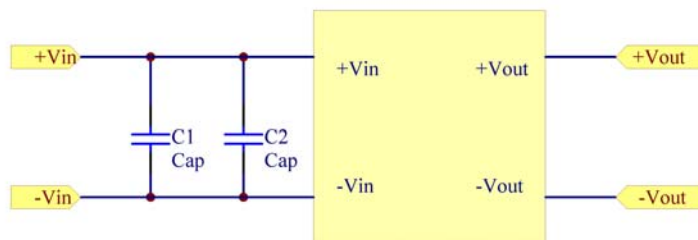

Uin 24V: C1 6.8uF/50V; C2 6.8uF/50V

Uin 48V: C1 2.2uF/100V; C2 2.2uF/100V

Derating

Typical Derating curve for Natural Convection

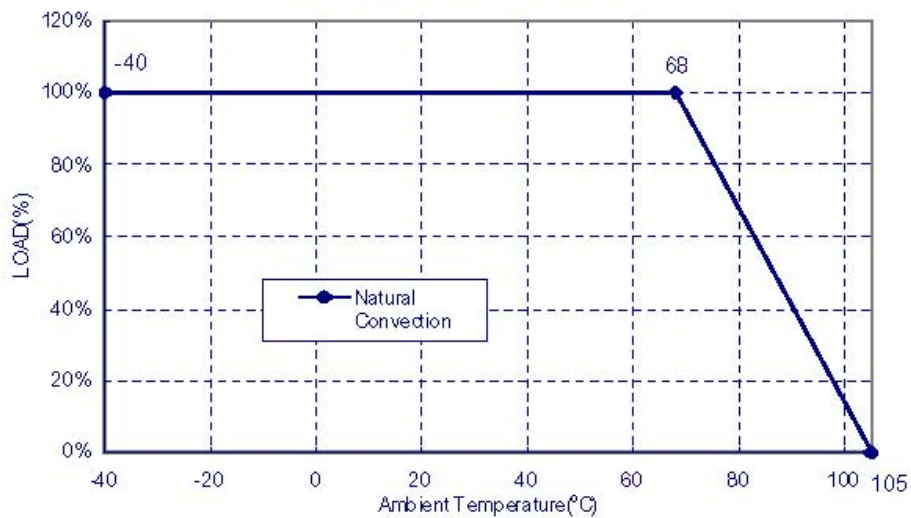

Functional block diagram

Blockschema

Synoptique

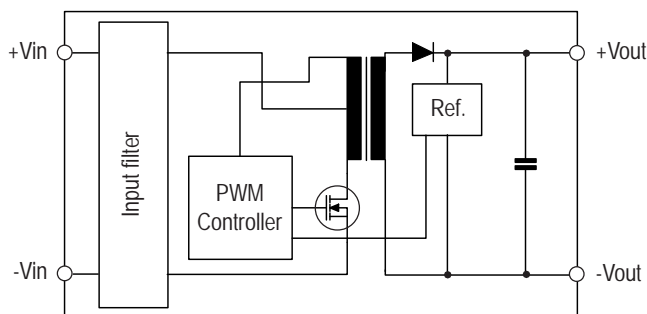

Single output converter block diagram

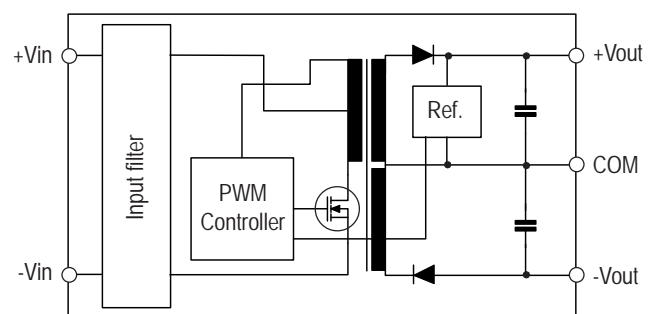

Dual output converter block diagram

Soldering Information

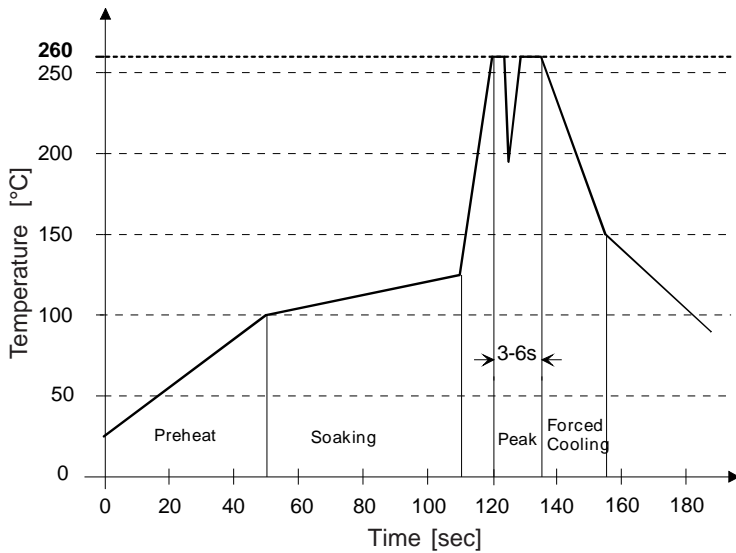

Limits:

Preheat: Ramp up rate during preheating is 1.4°C/sec; from 50°C to 100°C.

Soaking: Ramp up rate during soaking is 0.5°C/sec; from 100°C to 130°C (60 ± 20sec).

Peak: Peak temperature is 260°C and maximum 3-6 sec above 250°C is allowed.

Cooling: Ramp down rate during forced cooling is -10°C/sec from 260°C to 150°C.

External output voltage trim

For the ECU 15W SB series, the trim function allows the user to adjust the output voltage between ±10% by connecting an external resistor either between the trim pin and the common pin (trim-up) or the trim pin and the +Uout pin (trim-down).

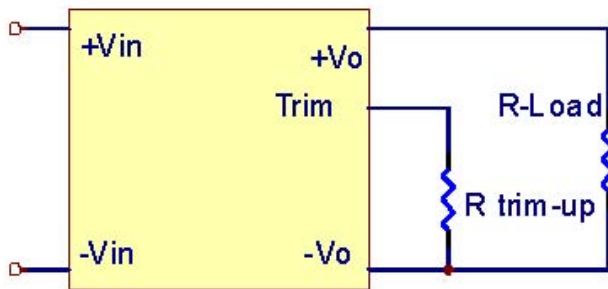

Figure 1. Trim-up Voltage Setup

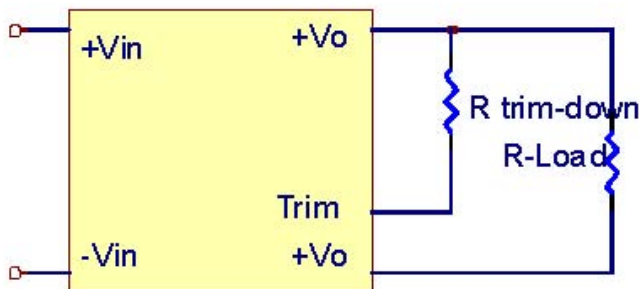
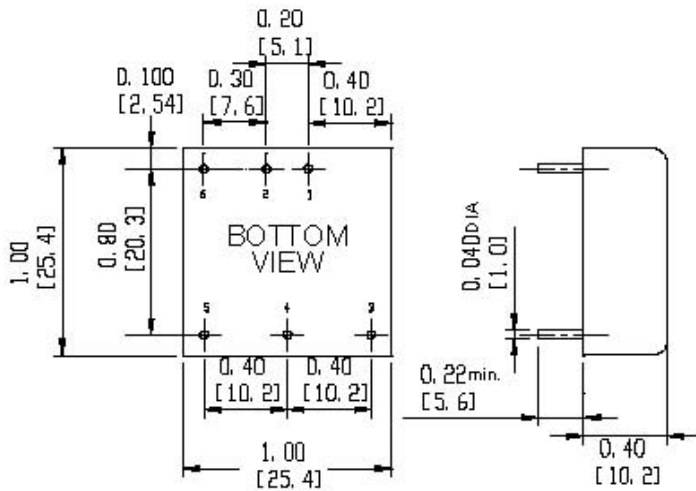

Figure 2. Trim-down Voltage Setup

View from bottom; Normal tolerance ± 1.0 mm; Pin distance tolerance ± 0.05 mm; Round pins 1.0 mm diameter



PIN CONNECTION		
Pin	DIP Function	
	Single	Dual
1	+Input	+Input
2	-Input	-Input
3	+V Output	+V Output
4	Trim	Common
5	-V Output	-V Output
6	Remote ON/OFF	Remote ON/OFF

Cleaning

Waschen

Lavage

The modules are cleanable with the today's known and in the electronics industry usually used products.

Due to the different cleaning processes and new available products, we highly recommend to do a compatibility test when using the converters the first time.

Die Module sind waschbar mit den heute bekannten und in der Elektronikindustrie üblichen Reinigungsmitteln.

Bedingt durch die verschiedenen Reinigungsprozesse und neu auf den Markt kommenden Mittel, raten wir dringend, beim Ersteinsatz der Konverter eine Verträglichkeitsprüfung vorzunehmen.

Les modules sont lavables avec les solvants couramment utilisés dans l'industrie électronique.

Dû aux différents processus de lavage et aux nouveaux détergents disponibles sur le marché, il est strictement recommandé de faire un test de compatibilité avant la première utilisation.

Notice: All statements, technical information, and recommendations related to FABRIMEX's products are based on information believed to be reliable, but the accuracy or completeness thereof is not guaranteed. Before utilizing the product, the user should determine the suitability of the product for its intended use.

Switzerland:
FABRIMEX AG • Techcenterstrasse 2
CH-8608 Bubikon
Tel: +41-55-253 31 90 • Fax: +41-55-253 31 91
Internet: www.fabrimex.com
Germany:
CAC FABRIMEX GmbH • D-89543 Gerstetten
Tel: 07323/ 950-0 • Fax: 07323/ 95050

FABRIMEX
POWER SUPPLIES